

FLEXISTAR™

Brought to you by HUI

Mighty and modular.

Find a home for medium to large-scale medical devices with a cart that can hold its own.

A robust workspace in a practical package.

Our FlexiStar™ standard cart is capable and customizable. Scope holders, footswitches, tank holders and more all find a home on the FlexiStar's sturdy frame.

Get ample storage on a compact, mobile platform. A large top work surface and multiple lower storage options give your customers what they need at the point-of-care.

FlexiStar™ is designed to maximize capacity for multiple applications while not compromising on safety and ergonomics. With four 5" medical-grade casters and a footprint designed to move easily through door frames, this cart offers mobility and freedom of movement.



Quality Construction

Built to IEC 60601-1 Standards

Manufactured on-site
in our midwest facility

Machined or casted
metal components

Generous Capacity

Cart capacity: 160 lbs.

Wide drawer and bin options
for larger devices

Diverse Applications

Endoscopy Cart

ENT

Respiratory Care

Anesthesia Workstation

FLEXISTAR™

Expedite your speed to market.

Contact sales@huimfg today to get started!

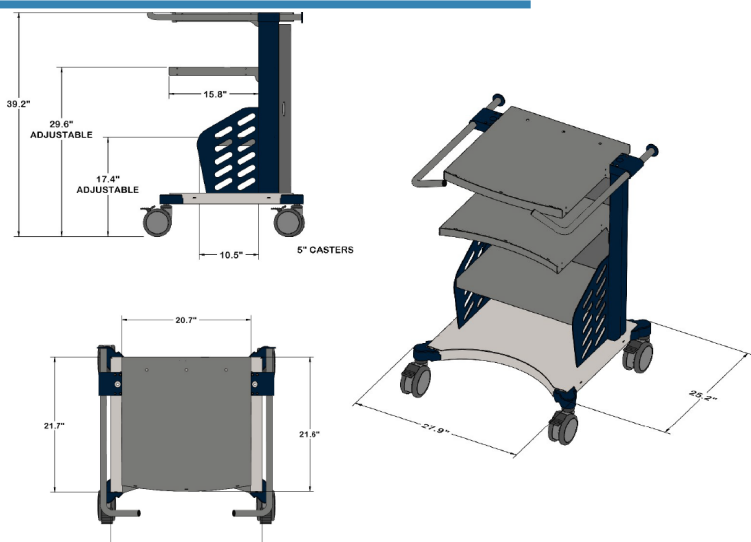

FlexiStar Baseline Dimensions:

- Height: 39.2"
- Base: 24.5" x 21.7"
- Cart Weight: 102 lbs.
- Casters: 4 x 5" locking casters

Customizable Features:

- Sturdy lower shelves, drawer kit, or bin
- Optional keyboard tray mounted beneath work surface
- Professionally-matched powder-coat color and finish

Accessory Options:

- Add monitor or tablet mount to top work surface
- Tank-mounting brackets can be added to rear
- Add baskets, IV pole mounts, and more!

Shipping and Assembly:

- Ships fully-assembled
- Easily remove back panel for required access
- Packaging is engineered to minimize damage in transit

