



VERSASTARTM

VersaStar Standard Medical Cart

Our VersaStar is a small device cart with multiple shelves that is capable of holding a wide range of devices. Feel free to discuss additions such as additional shelves, baskets, tank brackets, IV poles, bins, cord wraps and so much more!



VersaStar Optional Features

Enjoy features and functionalities often reserved for custom applications without the custom price, large quantities, or lead time.

- Built to ISO 60601 standards
- Customization metal top
- Bent tube handle (up or down, front or rear)
- Stock Basket Options
- Square Center Column
- Height Adjustable Column
- Printer Shelf
- Power Brick Holder
- Weight Plates
- Five 4" locking casters



HUI
CENTERED AROUND YOU

10 East Park Ave, Kiel WI 53042
920-894-2233
www.medicalcarts.org

Customized Options

VersaStar models feature many standard features to meet most needs, yet can be configured to meet your exacting specifications, including custom:

- Customizable top work surface
- Basket Sizes
- Mounting holes for devices
- Variety of articulating arms
- Cylinder tank holder brackets
- Cable Wraps
- Machined or casted metal features
- Foot switch
- And more



Dimensions

Max top shelf weight 20 lbs

Max equipment weight 60 lbs

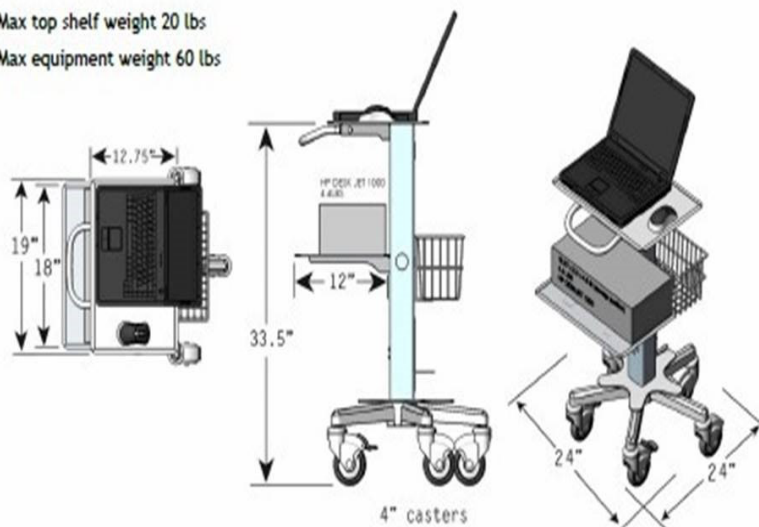

VersaStar Baseline Dimensions

- Height 33.5"
- Base: 24"x24"
- Lower shelf: 12"x19"
- Top Surface: 12.75" x 19"
- Cart Weight: 50-60lbs
- Casters: 4"

Please Contact
HUI's Medical Business
Development Team
1-800-877-8913
MBD@huimfg.com

